



**DESAN**

# **ROBOTIC WELDING**

SOLUTIONS FOR ALL INDUSTRIES



Industrial Robot Positioner



# Type analysis

---

**DP** **HT** **###** **.** **H** **1** **2** **-** **1000**

①

②

③

④

⑤

⑥

⑦

⑧

⑨

① Desan Positioner

② HT -Head Tail;  
HX -Head only;

FT -Floor Table;

TR -Tilt Rotary ;

DC -Drop Center;

SH -Sky Hook;

FW -Ferris Wheel;

③ Payload Capacity kg;

④ . Separator;

⑤ H: Horizontal indexing ;

V: Vertical indexing;

N: No indexing;

⑥ #: Number of Station;

⑦ #: Number of Axis;

⑧ - Separator;

⑨ Auxiliary parameter;  
e.g part long ;

**CODE**



# Type analysis

Index axis  
(change station)

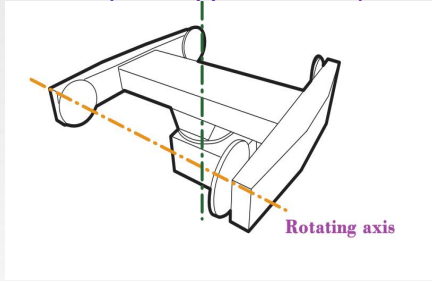

Index axis  
(change station)

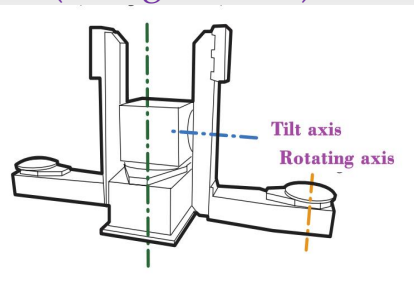

H models  
(horizontal indexing)



V models  
(Vertical indexing)

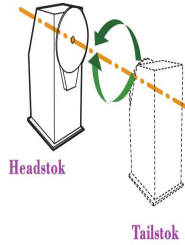
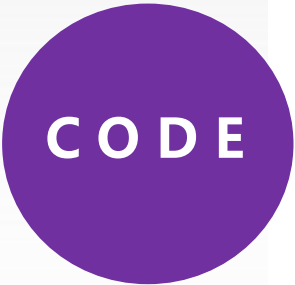
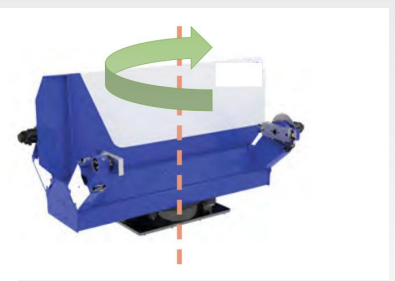

One station

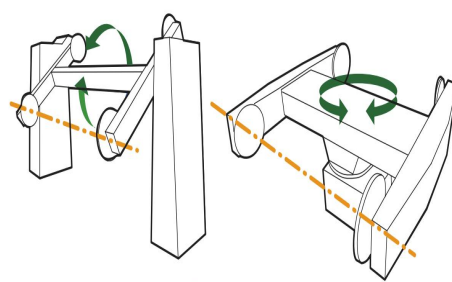

Two station

One axis for workpart that require rotation around one axis

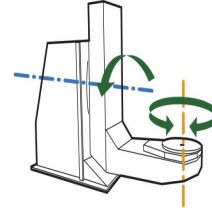

one station

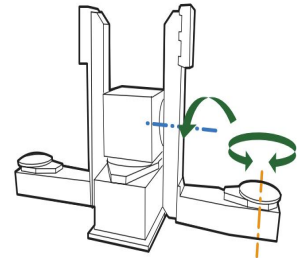

two station

Two axis for workpart that require rotation around two axis



# Type analysis

---

## How to Pick the Best Robotic Positioner for You

You will want to consider questions like:

- +1 How much space do we have to fit the robot and positioner?
- +2 What is the geometry of our workpieces?
- +3 Are the workpieces too large or heavy for a single positioner?
- +4 What style of positioner makes the most sense?
- +5 What payload does the positioner require?

Once you have determined the best type of positioner, have a look at the various manufacturers of robotic positioners to find a suitable model.



**Pick**



# Type analysis

How to Pick the Best Robotic Positioner for You



Head Tail type



Floor Table type



Tilt Rotary type



Sky Hook type



Head X type



Floor Track



Drop Center type



Ferris Wheel type

Pick



### Head Tail

### Head X

### Floor Table

### Tilt Rotary

### Drop Center

### Sky Hook

### Ferris Wheel

Model	DPHT250.N11-1800	DPHT500.N11-1800	DPHT1000.N11-1800	DPHT250.N11-2500	DPHT500.N11-2500	DPHT1000.N11-2500	DPHT2000.N11-3000	DPHT300.N11-3000
Payload(kg)	250	500	1000	250	500	1000	2000	3000
Height(rotation center) (mm)	650						950	
Framesize(mm)	1800×800			2500×800			3000×800	
Rotating speed(°/s)	78	78	74	78	78	74	64.5	22.63
Repeat ability(arcmin)	±1.0	±1.0	±1.2	±1.0	±1.0	±1.2	±1.2	±1.8
Rotary angle(°)	±360							
ECC.distance(mm)	≤150		≤100	≤150		≤100		≤80
GC.distance(mm)	≤300		≤200	≤300		≤200		≤150
RV reducer	40E-153	80E-153	110E-161	40E-153	80E-153	110E-161	320E-185	
Gear ratio	153		161	153		161	185	530.34
Motor power(kw)	1.5	2.0	3.0	1.5	2.0	3.0	3.0	4.3

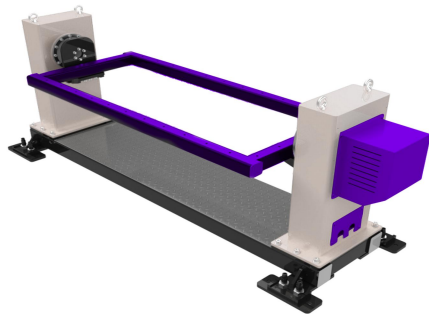



### Head Tail

### Head X

### Floor Table

### Tilt Rotary

### Drop Center

### Sky Hook

### Ferris Wheel

Model		DPHT250.H23-1800	DPHT500.H23-1800	DPHT1000.H23-1800	DPHT250.H23-2500	DPHT500.H23-2500	DPHT1000.H23-2500
Payload(kg)		250	500	1000	250	500	1000
Framesize(mm)		1800*800			2500*800		
Rotating speed(°/s)	Outer axis	64	64	22.63	64	64	22.63
	Inner axis* 2	78	78	70	78	78	70
Repeatability(arcmin)		±1.5					
Rotary angle()		Outer axis: ±180; Inner axis: ±360					
ECC.distance(mm)		≤100					
GC.distance(mm)		≤150					
RV reducer	Outer axis	320E-185					
	Inner axis* 2	40E-153	80E-153	160E153	40E-153	80E153	160E153
Gear ratio	Outer axis	185		530.34	185		530.34
	Inner axis* 2	153		171	153		171
Motor power(kw)	Outer axis	3.0					
	Inner axis* 2	1.5		3.0	1.5		3.0

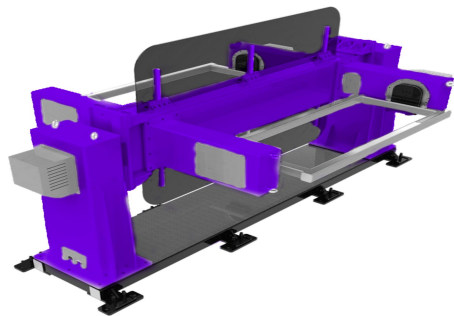



### Head Tail

### Head X

### Floor Table

### Tilt Rotary

### Drop Center

### Sky Hook

### Ferris Wheel

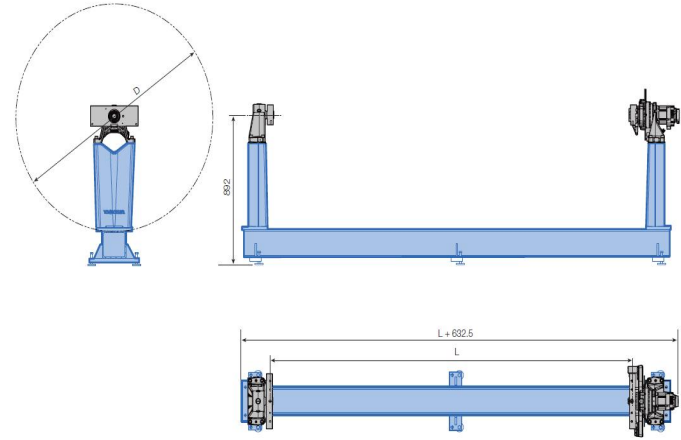
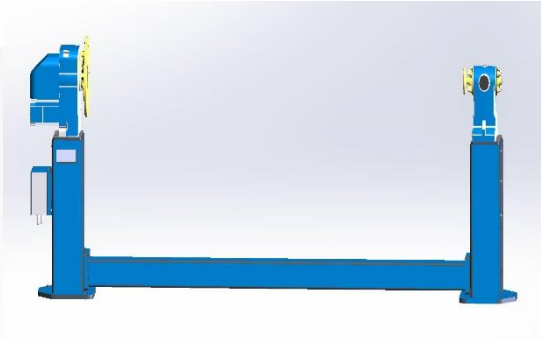
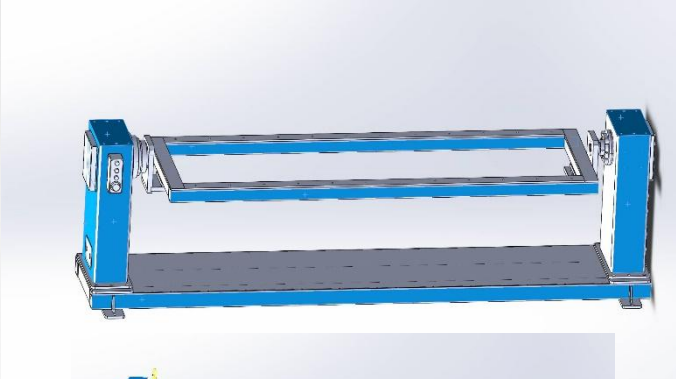

Type	L	D
DPHT-500	2050	1250
		1650
	3050	1250
		1650
	4050	1250
		1650
<i>Other lengths on demand.</i>		
DPHT-1000	2050	1250
		1650
	3050	1250
		1650
	4050	1250
		1650
<i>Other lengths on demand.</i>		



Head Tail

Head X

Floor Table

Tilt Rotary

Drop Center

Sky Hook

Ferris Wheel

Model		DPHX250.N12-1800	DPHX500.N12-1800	DPHX1000.N12-1800	DPHX2000.N12-1800
Payload(kg)		250	500	1000	2000
Framesize(mm)		1800*800			
Rotating speed(°/s)	Tilting axis	42.7	12.5	12.5	11.66
	Rotating axis	78	78	70	64.86
Repeatabilty(arcmin)		±1.5			±2.0
Rotary angle()		Tilting axis: ±180; Rotating axis: ±360			
ECC.distance(mm)		≤200	≤150		
GC.distance(mm)		≤100			
RV reducer	Tilting axis	200C—281	160E—171	160E—171	320E—185
	Rotating axis	40E—153	80E—153	160E—171	320E—185
Gear ratio	Tilting axis	281	951.19	951.19	1029.06
	Rotating axis	153	153	171	185
Motor power(kw)	Tilting axis	3.0	3.0	3.0	4.3
	Rotating axis	2.0	2.0	2.0	3.0



Head Tail

Head X

Floor Table

Tilt Rotary

Drop Center

Sky Hook

Ferris Wheel

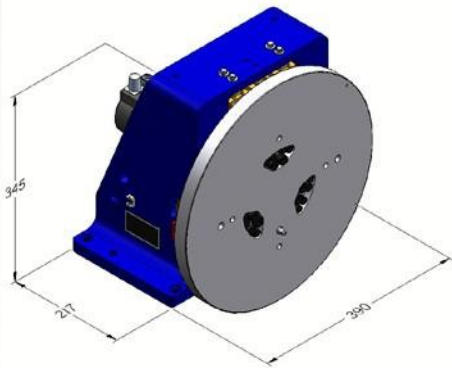
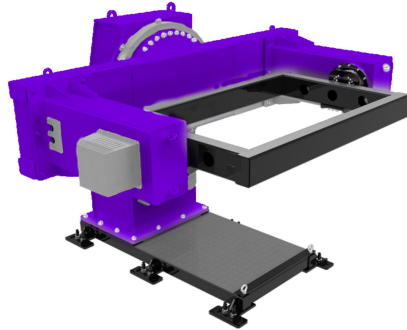

### DPHX-1000/H11

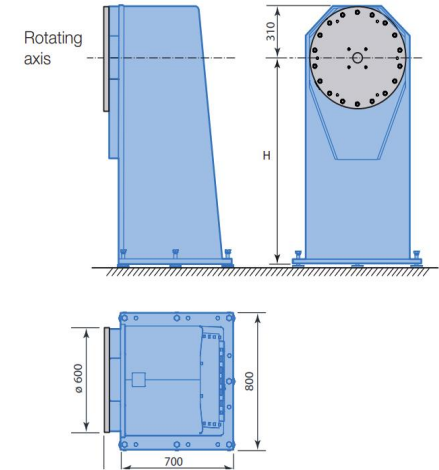
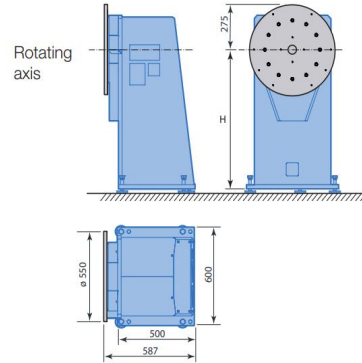

### DPHX-2000/H11

	H (mm)	Weight
DPHX-1000	650	313 kg
	850	340 kg
	970	356 kg
	1200	387 kg
DPHX-2000	1500	433 kg
	970	568 kg
	1200	616 kg
	1500	680 kg



Head Tail

Head X

Floor Table

Tilt Rotary

Drop Center

Sky Hook

Ferris Wheel

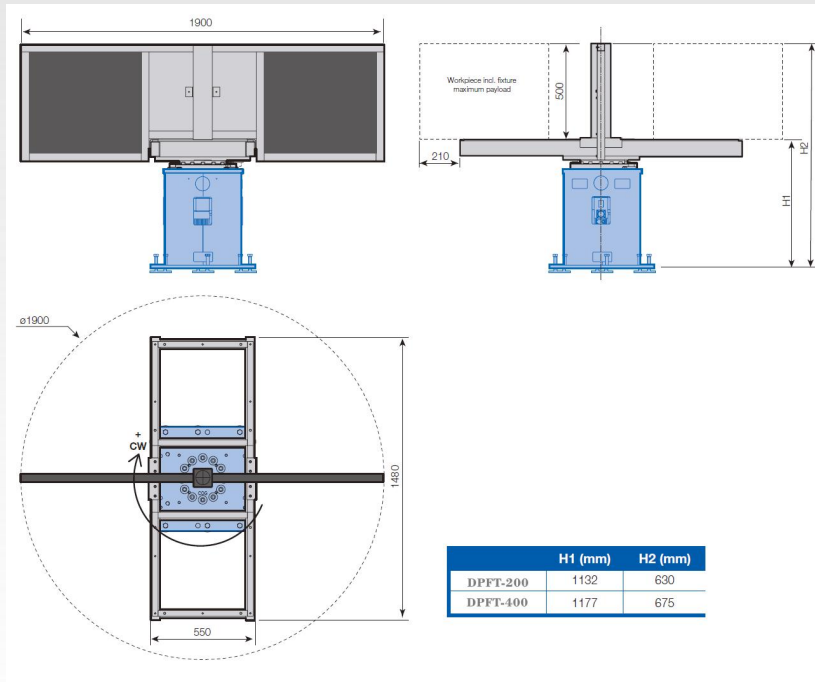
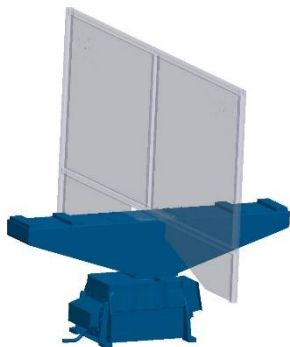
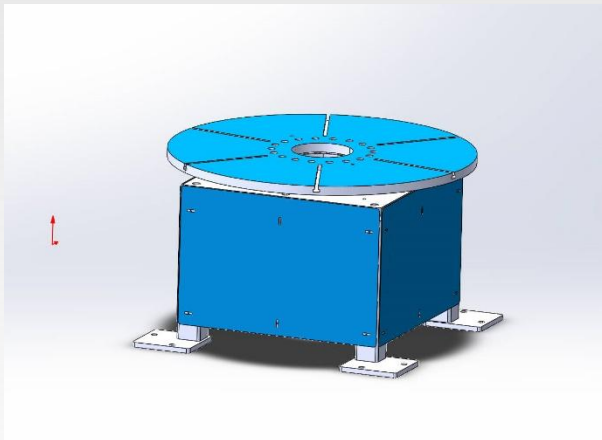



Head Tail

Head X

Floor Table

Tilt Rotary

Drop Center

Sky Hook

Ferris Wheel

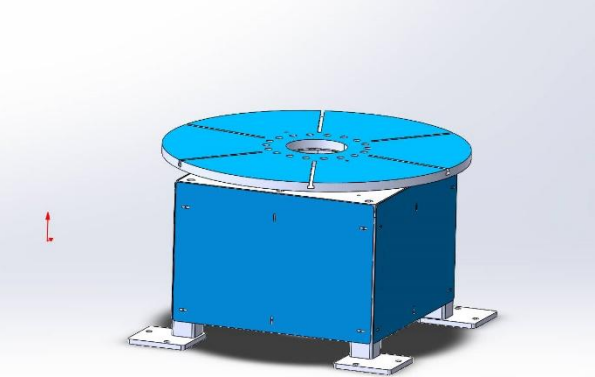

- For small- to medium-size parts
- Operator safely loads/unloads part(s) on one side of the positioner (outside the robot's work envelope), while the robot welds part(s) on the other side
- Metal arc screen divider creates barrier; safeguards operator from arc flash
- Run same part(s) on both sides of positioner or run one part on Side A and different part on Side B
- H-frame table top; low-inertia and quick-change tooling
- Options: tooling plates, 72" table top and slip rings for utilities

Model	DPFT250.N11	DPFT500.N11	DPFT750.N11
Payload(kg)	250	500	750
Table diameter(mm)	400		
Rotating speed(°/s)	76.4	67.8	45.3
Repeatability(arcmin)	±1.0		
Rotary angle(°)	±360		
ECC.distance(mm)	≤200		
GC.distance(mm)	≤200		
RV reducer	27C—157	50C—177	100C—264.6
Gear ratio	157	177	264.6
Motor power(kw)	1.0	2.0	

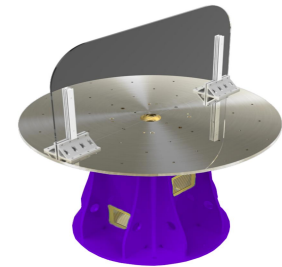



- Head Tail
- Head X
- Floor Table
- Tilt Rotary
- Drop Center
- Sky Hook
- Ferris Wheel

Model		DPTR250	DPTR500
Payload(kg)		250	500
Table diameter(mm)		800	
Rotating speed(°/s)	Tilting axis	78	45
	Rotating axis	76.4	67.7
Repeatabily(arcmin)		±1.5	
Rotary angle(°)		Tilting axis: ±90; Rotating axis: ±360	
ECC.distance(mm)		≤100	
GC.distance(mm)		≤100	
RV reducer	Tilting axis	40E-152	100C-264.6
	Rotating axis	27C-157	50C-177
Gear ratio	Tilting axis	153	264.6
	Rotating axis	157	177
Motor power(kw)	Tilting axis	2.0	3.0
	Rotating axis	1.5	2.0

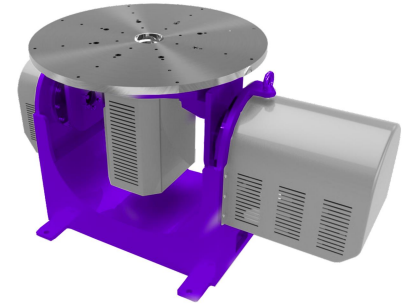
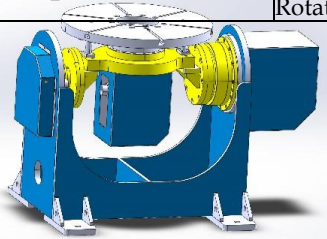
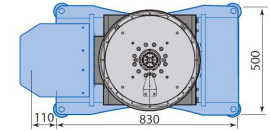
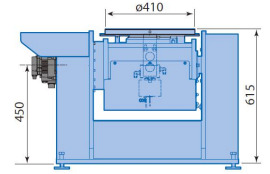
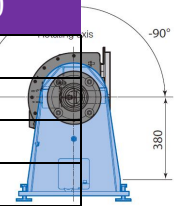



Multi-axis positioners provide added application flexibility. Many provide two axes, allowing most welding to be done in the optimum position, thereby increasing travel speeds. DESAN software supports the coordination of both axes with robot motion.

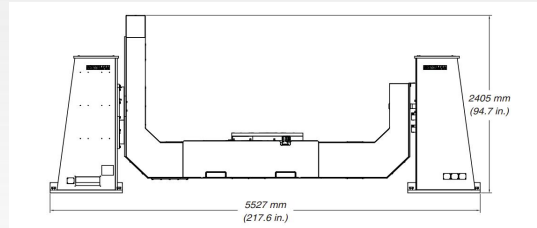
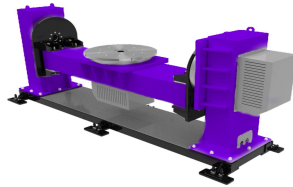
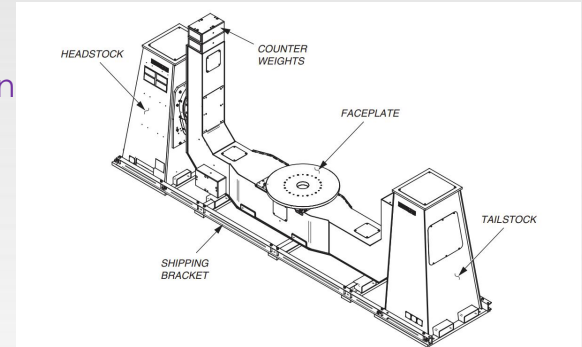

Head Tail

Head X

Floor Table

Tilt Rotary

Drop Center

Sky Hook

Ferris Wheel

Model	DPDC250.N12-1200	DPDC500.N12-1200	DPDC250.N12-1400	DPDC500.N12-1200	DPDC1000.N12-1500	DPDC1000.N12-1600	
Payload(kg)	250	500	250	500	1000	1000	
Table diameter(mm)	1200		1400		1500	1600	
Rotating speed(°/s)	Tilting axis	45				42	
	Rotating axis	67.7				42	
Repeatability(arcmin)	±1.0				±1.5		
Rotary angle(°)	Tilting axis: ±90; Rotating axis: ±360						
ECC.distance(mm)	≤100						
GC.distance(mm)	≤200						
RV reducer	100C264.6						200C281
	Rotating axis	27C—177	50C—177	27C—177	50C—177	200C—281	200C—281
Gear ratio	264.6						281
	Rotating axis	157	177		281		
Motor power(kw)	3.0						
	Rotating axis	1.5	2.0	1.5	2.0	3.0	3.0



Head Tail

Head X

Floor Table

Tilt Rotary

Drop Center

Sky Hook

Ferris Wheel

Model		DPSH250.N1 2-800	DPSH500.N1 2-800	DPSH1000.N 12-1200	DPSH2000.N 12-12800
Payload(kg)		250	500	1000	2000
Table diameter(mm)		800		1200	
Rotating speed(°/s)	Tilting axis	45.3	42	12.6	11.66
	Rotating axis	76.43	67.8	42.7	24.48
Repeatability(arcmin)		±1.5		±1.8	
Rotary angle(°)		Tilting axis: ±180; Rotating axis: ±360			
ECC.distance(mm)		≤200	≤250	≤250	≤150
GC.distance(mm)		≤200	≤300	≤300	≤200
RV reducer	Tilting axis	100C—264.6	200C—281	160E—171	320E—185
	Rotating axis	27C—157	50C-177	200C-281	160E—171
Gear ratio	Tilting axis	264.6	281	1029.06	1029.06
	Rotating axis	157	177	281	490.21
Motor power(kw)	Tilting axis	3.0	3.0	3.0	4.3
	Rotating axis	1.5	2.0	2.0	3.0

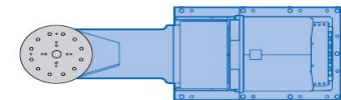
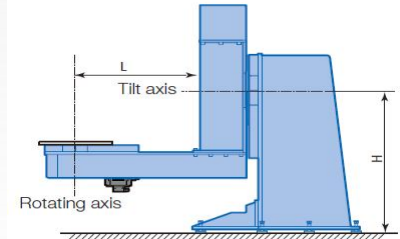
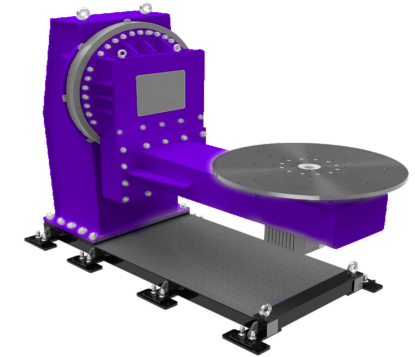



Head Tail

Head X

Floor Table

Tilt Rotary

Drop Center

Sky Hook

Ferris Wheel

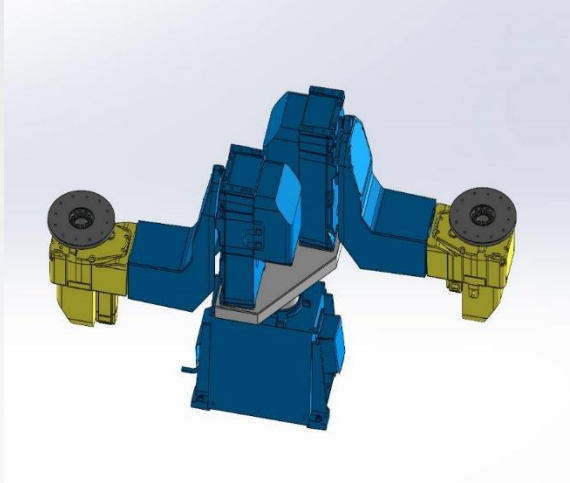

### Double-Ended Skyhook Positioner

- Suited to box structures and tubular frames
- Coordinated two-axis positioning for best joint access
- In-line design; sides A and B in same position to simplify programming

#### DPSH-900/X25

Payload	900 kg @ 152mm off-center, 500 mm overhang
Sweep Time	7 sec.
Turn Speed	TILT: 12.9 rpm, ROTATE: 12.4 rpm
Max Part Size	1m tall x 1.76m dia.
Torque (Static)	1,276 N•m
Offset Dimension (X,Y)	248 mm, 880 mm

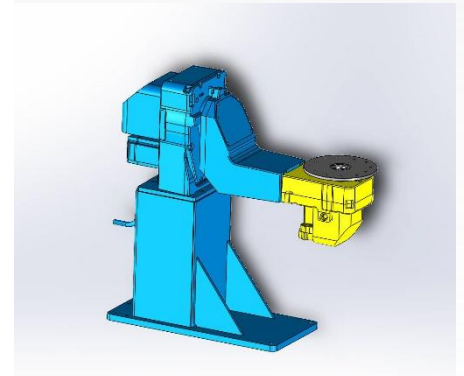
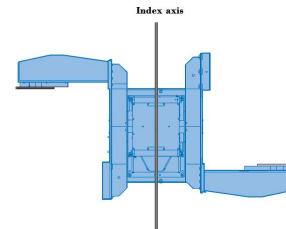
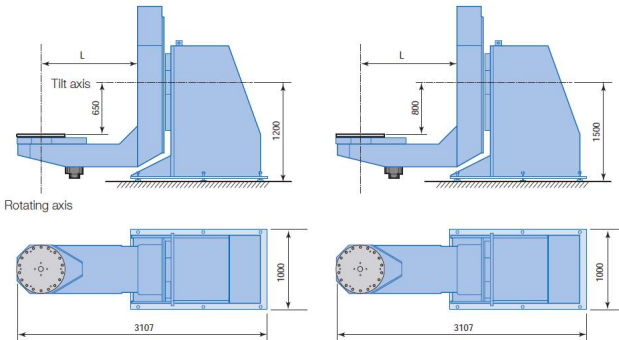
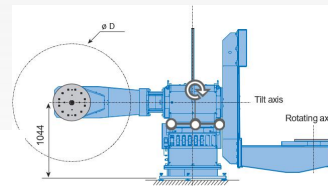



Head Tail

Head X

Floor Table

Tilt Rotary

Drop Center

**Sky Hook**

Ferris Wheel

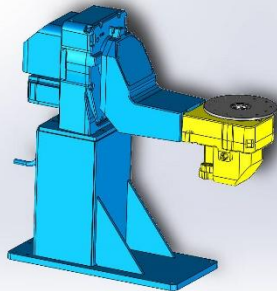
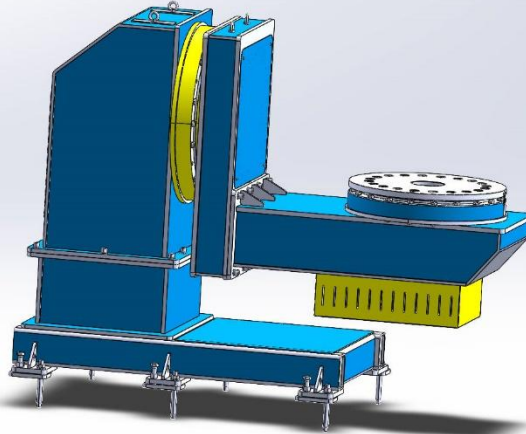

### SH – Skyhook Positioner

- Suited to heavier parts such as construction equipment frames
- Offset “Skyhook” design keeps part on center while tilting
- Thru-hole in faceplate for utilities

	DPSH-1500	DPSH-3000	DPSH-5000
Payload	1,500 kg	3,000 kg	5,000 kg
Offset X, Y	272 mm, 180 mm	462 mm, 321 mm	283 mm, 197 mm
Tilt	0-4.5 rpm	0-1.9 rpm	0-1.9 rpm
Rotate	0-6.9 rpm	0-2.7 rpm	0-2.7 rpm
Max Part Size	1,500 mm L x 2,390 mm dia.	2,335 mm L x 3,600 mm dia.	1,875 mm L x 2,600 mm dia.
Torque (Static)			
X, Tilt	4,080 N•m	13,880 N•m	13,880 N•m
Y, Tilt	2,680 N•m	9,650 N•m	9,690 N•m

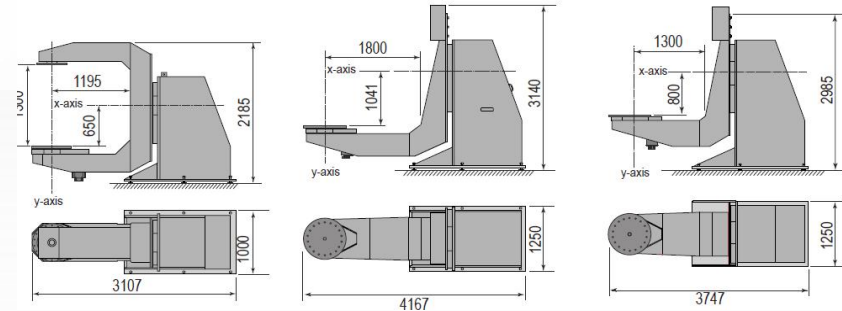



Head Tail

Head X

Turn Table

Tilt Rotary

Drop Center

Sky Hook

Ferris Wheel

Model		DPFW250.V23-1800	DPFW500.V23-1800	DPFW1000.V23-1800	DPFW250.V23-2500	DPFW500.V23-2500	DPFW1000.V23-2500
Payload(kg)		250	500	1000	250	500	1000
Framesize(mm)		1800*800			2500*800		
Rotating speed(°/s)	Tilting axis* 2	78	78	74.5	78	78	74.5
	Rotating axis	42	24.48	11.66	42	24.48	11.6
Repeatabily(arcmin)		±1.5	±1.8	±1.8	±1.5	±1.8	±1.8
Rotary angle(°)		Tilting axis: ±180; Rotating axis: ±360					
ECC.distance(mm)		≤100					
GC.distance(mm)		≤150					
RV reducer	Tilting axis* 2	40E-153	80E-153	110E161	40E-153	80E-153	110E-161
	Rotating axis	200C-281	320C-202.36	320E-185	200C-281	320C-202.36	320E-185
Gear ratio	Tilting axis* 2	153		161	153		161
	Rotating axis* 2	281	202.36	1029.06	281	202.36	1029.06
Motor power(kw)	Tilting axis* 2	1.5		3.0	1.5	2.0	3.0
	Rotating axis	3.0	4.3		3.0	4.3	

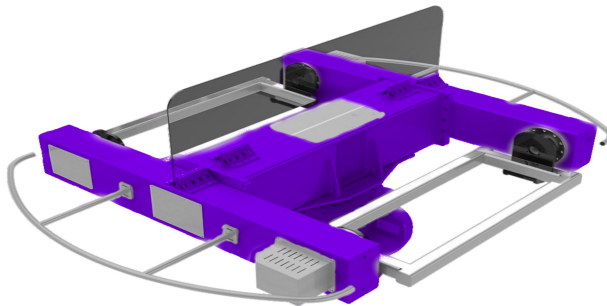

- Medium- to high-volume production
- Provides large turning diameter for shorter parts
- Three servo-motor control
  - All axes can turn simultaneously while indexing
  - Operator can jog station axis while robot welds
- Rotary axis motion can be coordinated with one or two robots
- Load position can be programmed in 30-degree increments
- Ergonomic loading and programming heights
- MotoMount fixture mounting system



Head Tail

Head X

Turn Table

Tilt Rotary

Drop Center

Sky Hook

Ferris Wheel

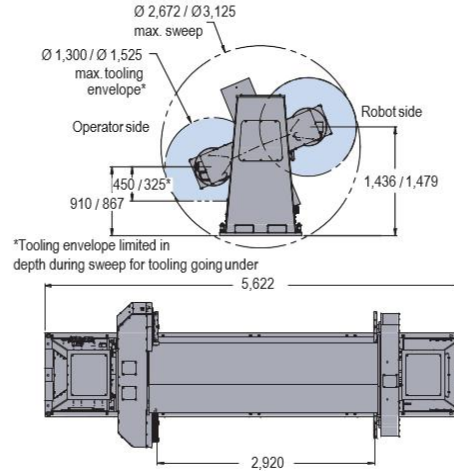
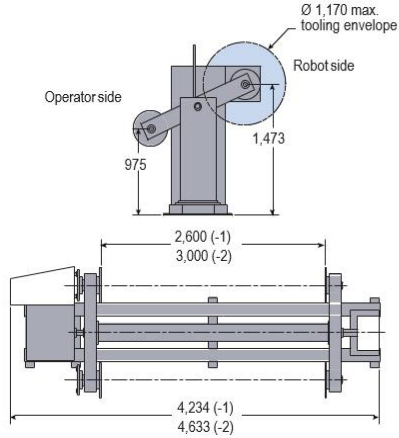

\*Tooling envelope limited in depth during sweep for tooling going under

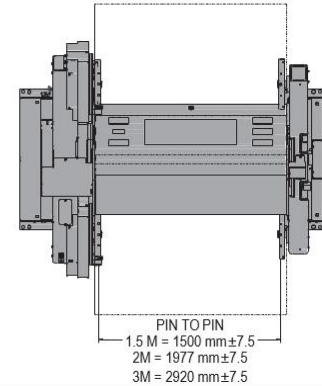
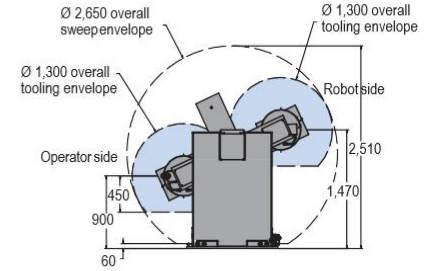

PIN TO PIN  
1.5 M =  $1500 \text{ mm} \pm 7.5$   
2M =  $1977 \text{ mm} \pm 7.5$   
3M =  $2920 \text{ mm} \pm 7.5$



Head Tail

Head X

Turn Table

Tilt Rotary

Drop Center

Sky Hook

Ferris Wheel

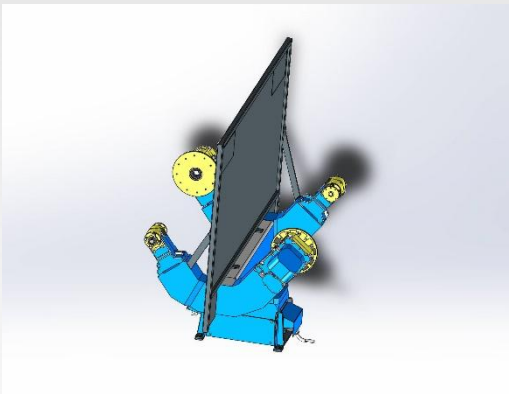

This is a two station positioner for workpieces that require rotation about one axis. It has been designed for operator ease of use, with a suitable working height for loading/unloading the fixtures, and is delivered complete with an anti-glare shield.

#### Available accessories

- Slip ring device
- Controlled air
- Fixture bracket

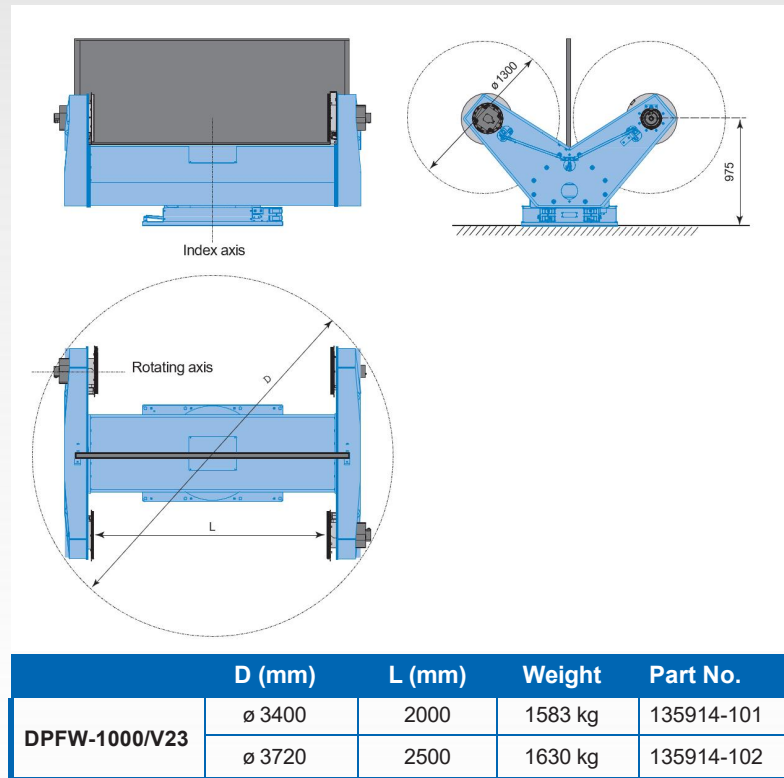



Head Tail

Head X

Turn Table

Tilt Rotary

Drop Center

Sky Hook

Ferris Wheel

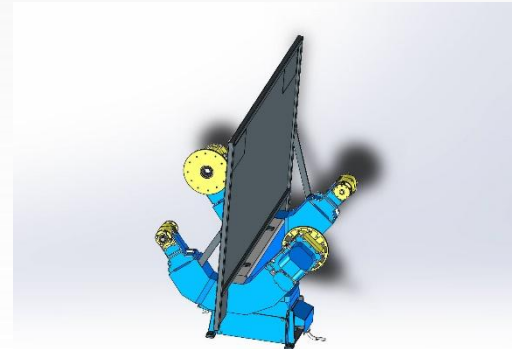
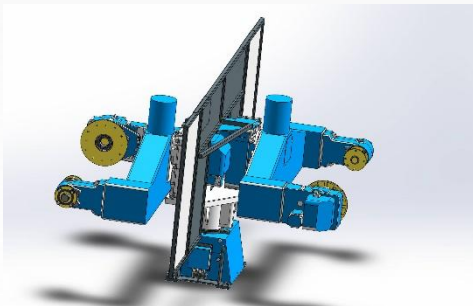
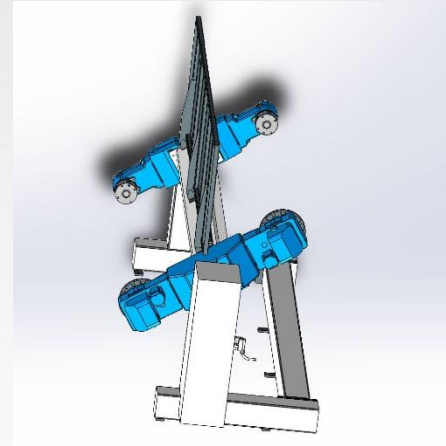
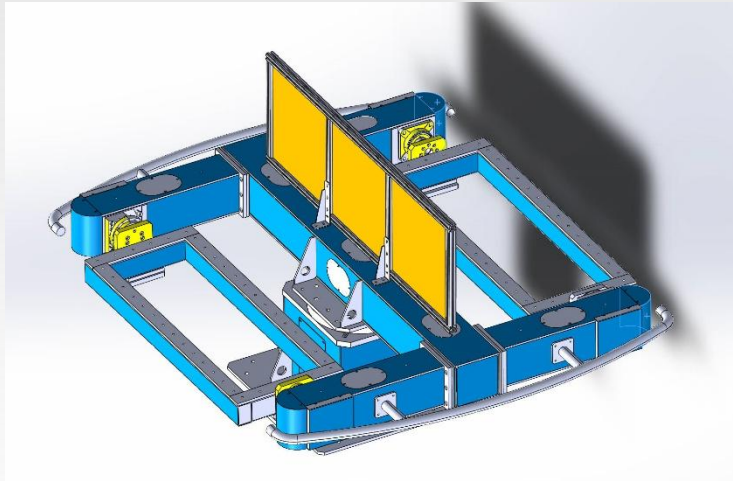



# Apply in

---

A

Robot &SH type

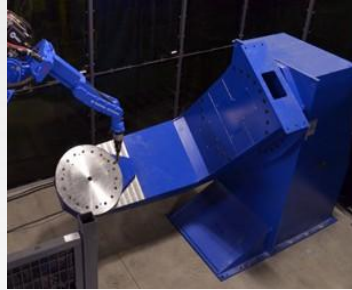

B

Indexing type

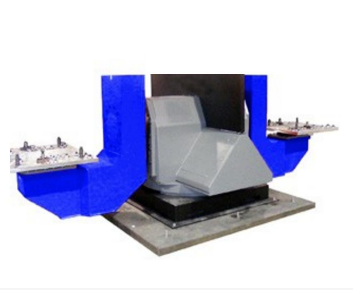

D

Rail track



C

Gantry type





# Apply in

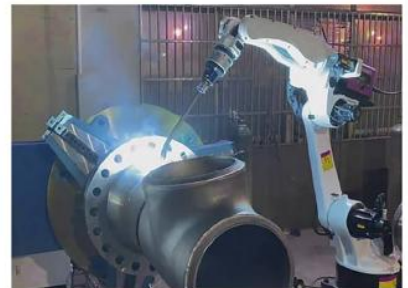
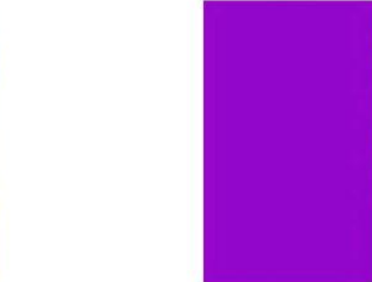
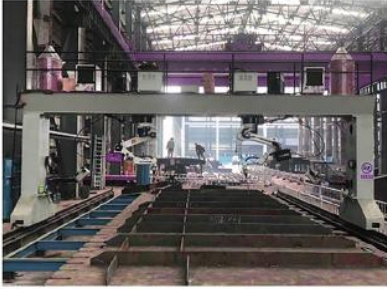



# 03

---

# ROBOT

---

01: Robot Para

02: Rail Track

03: Cantilever

04: Gantry

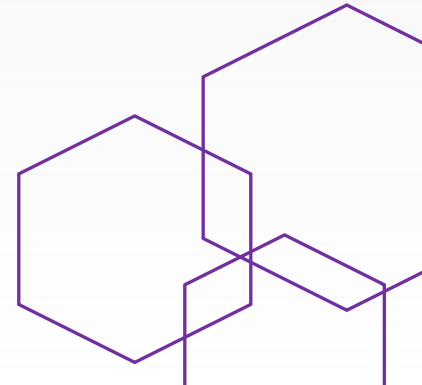



# Robot Parameter

## OPTIONS

- Extended length manipulator cables
- Robot risers
- Wide variety of fieldbus cards
- Vision systems
- Variety of weld packages
- Seam tracking and seam finding packages
- Functional Safety Unit (FSU)
- External axes

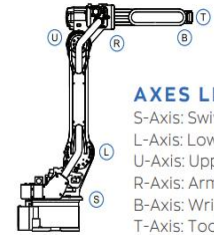

### AXES LEGEND

- S-Axis: Swivel Base
- L-Axis: Lower Arm
- U-Axis: Upper Arm
- R-Axis: Arm Roll
- B-Axis: Wrist Bend
- T-Axis: Tool Flange

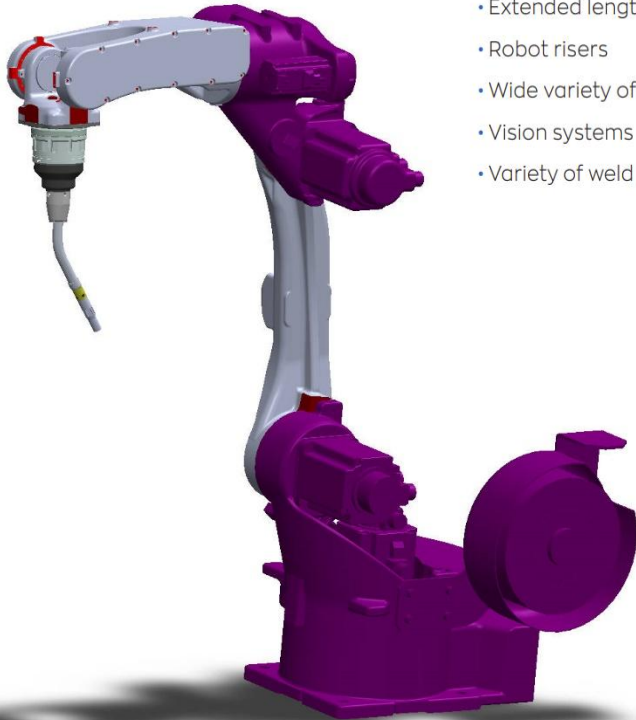

## SPECIFICATIONS

Axes	Maximum motion range	Maximum speed	Allowable moment	Allowable moment of inertia
	degrees	%/sec	N·m	kg·m <sup>2</sup>
S	±170	260	-	-
L	+155/-90	230	-	-
U	+140/-85	260	-	-
R	±150	470	22	0.65
B	+90/-135	470	22	0.65
T	±210	700	9.8	0.17

Mounting Options: Floor, Wall, Tilt or Ceiling

Item	Unit	AR1440
Controlled axes		6
Maximum payload	kg	12
Repeatability	mm	0.02
Horizontal reach	mm	1,440
Vertical reach	mm	2,511
Weight	kg	150
Internal user I/O cable		17 conductors w/ ground
Internal user air line		(1) 3/8" connection
Power requirements		380-480 VAC
Power rating	kVA	1.5



# Robot Parameter

## OPTIONS

- Extended length manipulator cables
- Robot risers
- Wide variety of fieldbus cards
- Vision systems
- Variety of weld packages
- Seam tracking and seam finding packages
- Functional Safety Unit (FSU)
- External axes

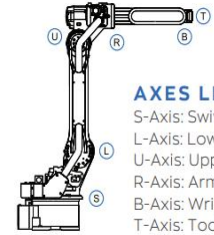

### AXES LEGEND

- S-Axis: Swivel Base
- L-Axis: Lower Arm
- U-Axis: Upper Arm
- R-Axis: Arm Roll
- B-Axis: Wrist Bend
- T-Axis: Tool Flange

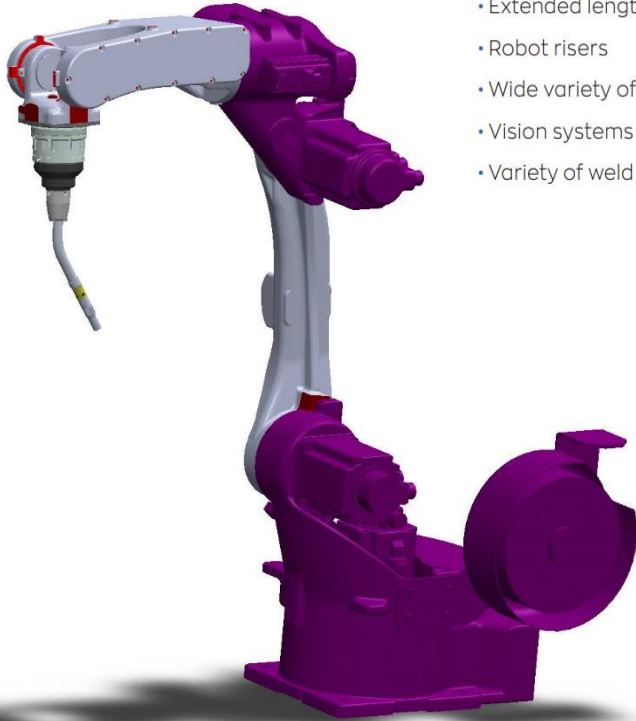

## SPECIFICATIONS

Axes	Maximum motion range	Maximum speed	Allowable moment	Allowable moment of inertia	Item	Unit	AR2010
	degrees	°/sec	N·m	kg·m <sup>2</sup>	Controlled axes		6
S	±180	210	-	-	Maximum payload	kg	12
L	+155/-105	210	-	-	Repeatability	mm	0.03
U	+160/-86	220	-	-	Horizontal reach	mm	2,010
R	±150	435	22	0.65	Vertical reach	mm	3,649
B	+90/-135	435	22	0.65	Weight	kg	260
T	±210	700	9.8	0.17	Internal user I/O cable		17 conductors w/ ground
					Internal user air line		(1) 3/8" connection
					Power requirements		380-480 VAC
					Power rating	kVA	2

Mounting Options: Floor, Wall, Tilt or Ceiling



# Robot Parameter

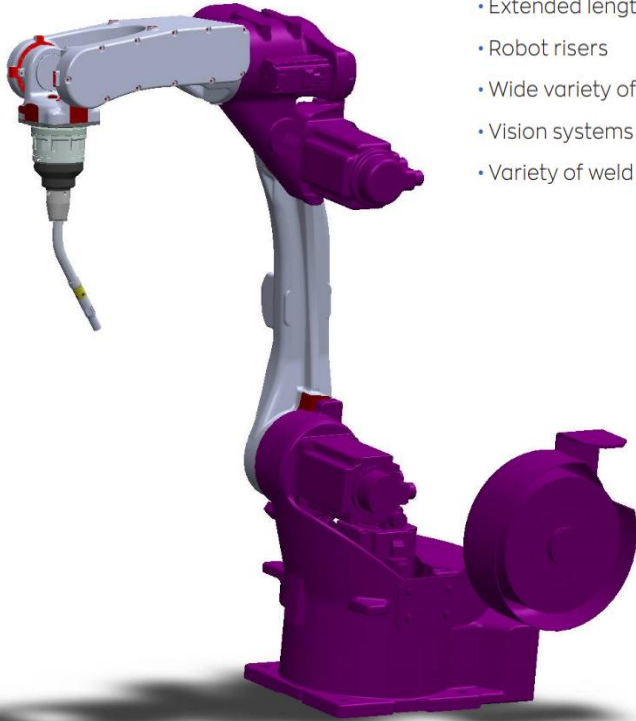

## OPTIONS

- Extended length manipulator cables
- Robot risers
- Wide variety of fieldbus cards
- Vision systems
- Variety of weld packages
- Seam tracking and seam finding packages
- Functional Safety Unit (FSU)
- External axes

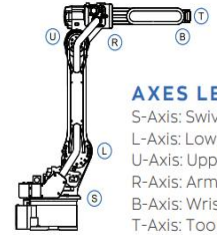

## AXES LEGEND

- S-Axis: Swivel Base
- L-Axis: Lower Arm
- U-Axis: Upper Arm
- R-Axis: Arm Roll
- B-Axis: Wrist Bend
- T-Axis: Tool Flange

## SPECIFICATIONS

Axes	Maximum motion range	Maximum speed	Allowable moment	Allowable moment of inertia	Item	Unit	AR1730
	degrees	°/sec	N·m	kg·m <sup>2</sup>	Controlled axes		6
S	±180	210	-	-	Maximum payload	kg	25
L	+155/-105	210	-	-	Repeatability	mm	0.02
U	+160/-86	265	-	-	Horizontal reach	mm	1,730
R	±150	420	52	2.3	Vertical reach	mm	3,089
B	+90/-135	420	52	2.3	Weight	kg	250
T	±210	885	32	1.2	Internal user I/O cable		17 conductors w/ ground
					Internal user air line		(1) 3/8" connection
					Power requirements		380-480 VAC
					Power rating	kVA	2

Mounting Options: Floor, Wall, Tilt or Ceiling



**Rail Track**

**Cantilever**

**Gantry**

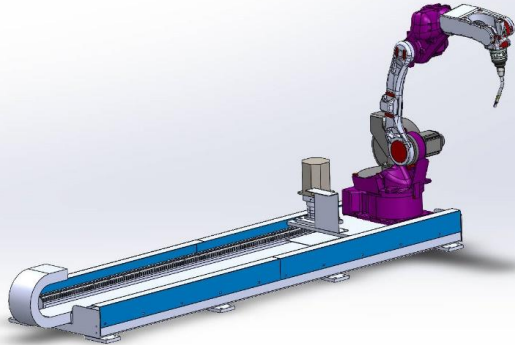

Model	RT1-500	RT-1000	RT-2000
Payload(kg)	500	1000	2000
Effective length(mm)	+1. 3m effective working length for 4m rail including base but without cover. +2. Maximum length of 1 module: 6m. +3. Effective working length decreases by 20% if cover is added.	+1. 2.5m effective working length for 4m rail, including base but without cover. +2. Maximum length of 1 module: 6m.	+1. 2.5m effective working length for 4m rail, including base but without cover. +2. Maximum length of 1 module: 6m.
Maximum speed(mm/s)	800	800	500
Repeatability(mm)	±0.1	±0.1	±0.15
Gear ratio	14.2742	13.407	20.8227
Motor power(kw)	1.5	3.0	3.0



**Rail Track**

**Cantilever**

**Gantry**

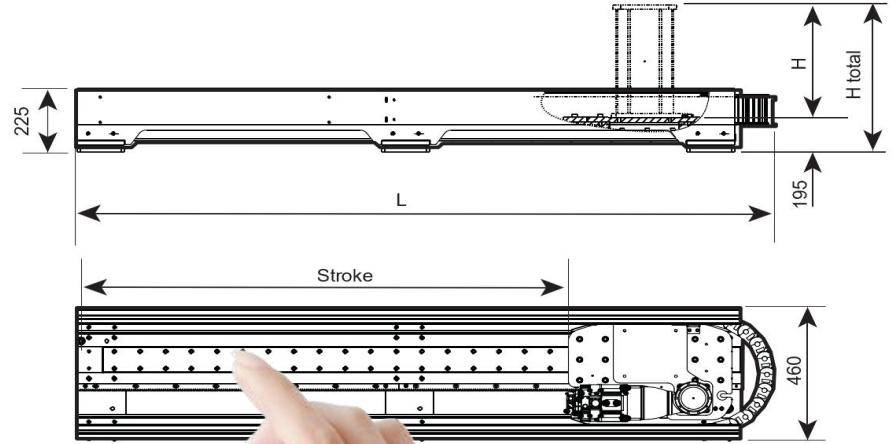

DTS-100D			
TS-100D, 20	60	1513	
TS-100D, 1	3146	2473	
TS-100D	4110	3433	

*All dimensions are for reference only.  
Request detailed drawings for design/engineering requirements!*



**Rail Track**

**Cantilever**

**Gantry**

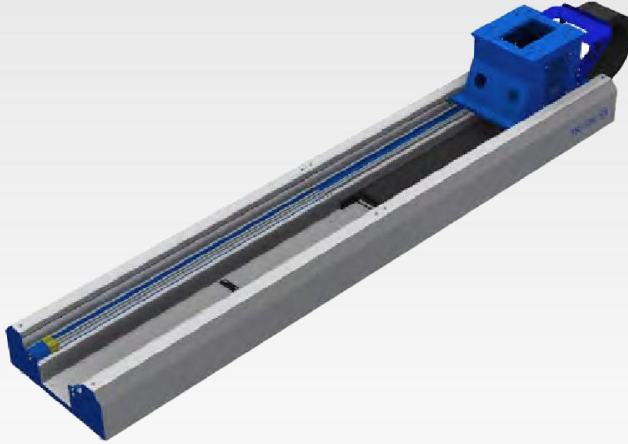

## Key benefits

- Outstanding speed.
- Quiet operation.
- For high payload robots.

This is a servo powered floor mounted track with one or two robot carriages. It can be used to transport a robot from one station to another, or to increase the robot's working range. The TSL track is prepared for zeroing function.

Since the track is built in two- or four meter modules, it is easy to extend to a suitable length.

Standard lengths up to 24 meters, and possible with longer tracks on request.

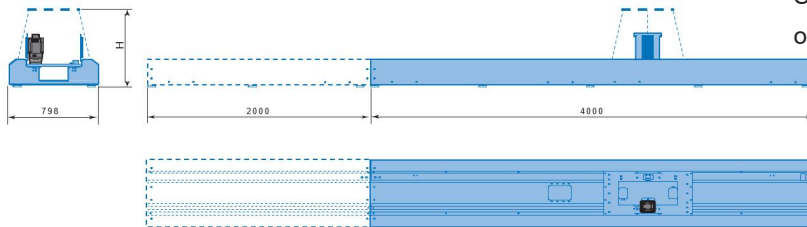

*All dimensions are for reference only.*

*Request detailed drawings for design/engineering requirements!*



**Rail Track**

**Cantilever**

**Gantry**

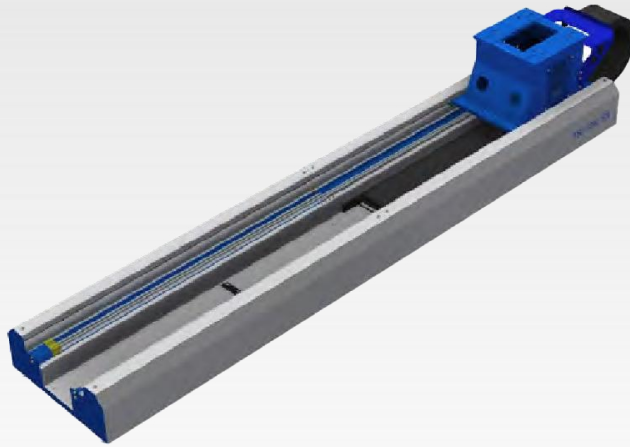

## Key benefits

Technical data	DTSL-1000
Maximum payload	1000 kg
Maximum speed	1.8 m/s
ED	50%
Acceleration velocity	1.6 m/s <sup>2</sup>
Travel length (TL)	1.0 sec
	1.38 sec
	500 mm 1000 mm
Repetitive position accuracy	±0.06 mm
Height (H) including robot stand	467*, 687, 887, 1087, 1287, 1487 mm
Standard length (L)	2, 3, 4 up to 24 meter (in 2 meter steps)
Travel length, stroke (TL)	L -850 mm (L -1065 mm)*

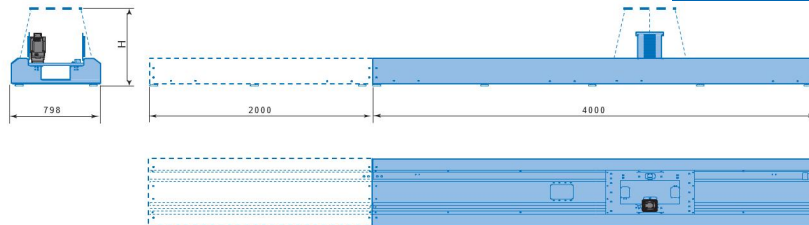

*All dimensions are for reference only.*

*Request detailed drawings for design/engineering requirements!*



**Rail Track**

**Cantilever**

**Gantry**

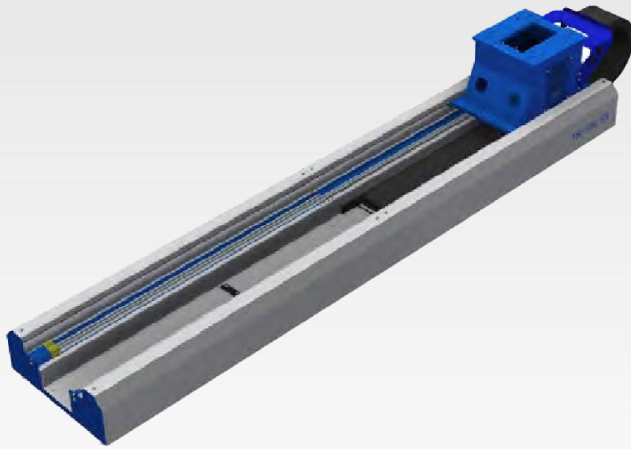

## Key benefits

Technical data	DTSL-2000	DTSL-4000
Maximum payload	<b>2000 kg</b>	<b>4000 kg</b>
Maximum speed	1.8 m/s	1.6 m/s
ED	50%	50%
Acceleration velocity	2.25 m/s <sup>2</sup>	2.0 m/s <sup>2</sup>
Travel 1200 mm	1.45 sec	1.55 sec
Repetitive position accuracy	±0.08 mm	±0.08 mm
Height	236 mm	236 mm
Height (H) including robot stand	461, 611, 811, 1334 mm	461, 611, 811, 1334 mm
Standard length (L)	2, 3, 4 up to 24m (in 2m/steps)	2, 3, 4 up to 24m (in 2m/steps)
Travel length, stroke (TL)	L -1340 mm	L -1340 mm

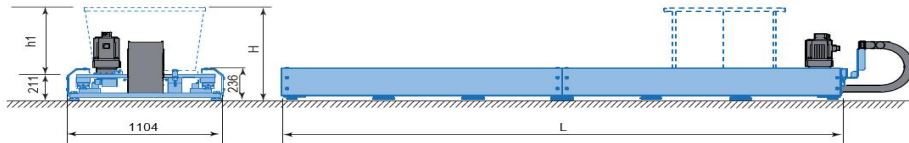

Optional robot stand	
h1 (mm)	H (mm)
250	461
400	611
600	811



*All dimensions are for reference only.*

*Request detailed drawings for design/engineering requirements!*



Rail Track

Gantry

Cantilever

The DG gantry is designed for reliable, accurate and economic robotic welding of very large components such as excavators, containers and earth moving equipment etc.

The DG is built up by two and four meter modules to any desired length with a suitable number of supporting pillars. They are servo powered and fully synchronized with the robot controller.

In twin systems, with several robots applied to the Y-beam, the robots can either work together or independent of each other.

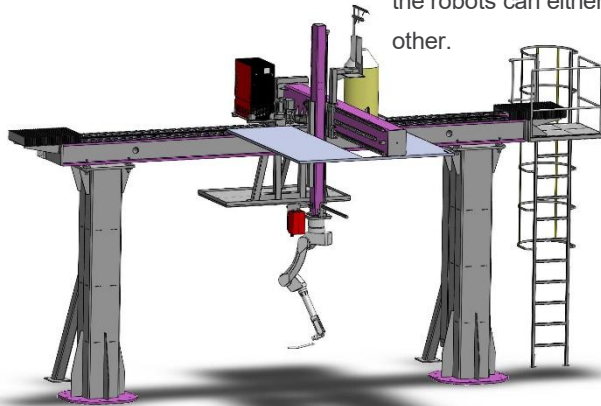

## Key benefits

- Outstanding speed.
- Single or twin robots.
- Cost efficient.

## Options

- Pillar height (H): 4300, 4600 or 4900 mm.
- Additional carriage.
- Zone limitations (up to four zones).
- Bracket mount for DG-Y.
- Accompanying wire barrel.



Rail Track

Gantry

Cantilever

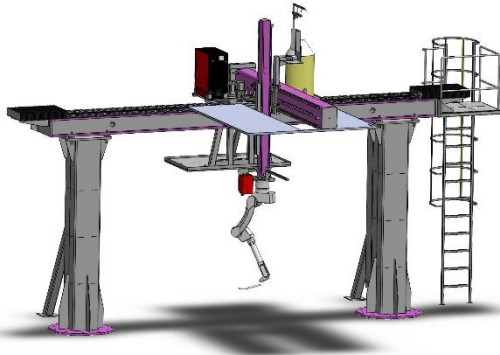
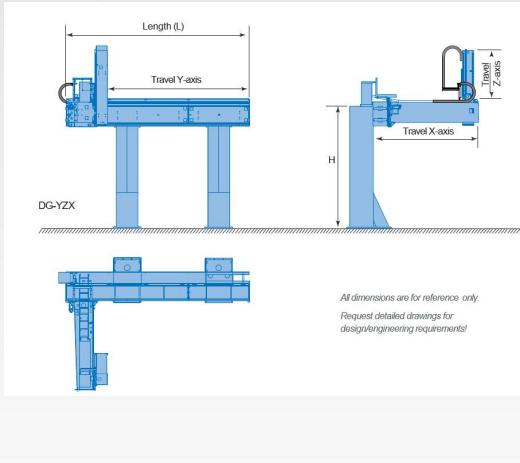

Technical data		DG-Y	DG-YX	DG-YZ	DG-YZX Std	DG-YZX
<b>Y AXIS</b>						
Travel length (TL)		L -975 mm	L -1100 mm	L -1100 mm	L -1100 mm	L -1100 mm
Standard length (L) in 2 meter steps		4-24 m	4-24 m	4-24 m	4-24 m	4-24 m
Standard pillar height		4 meter	4 meter	4 meter	4 meter	4 meter
Maximum speed	50% duty cycle	1.56 m/s	1.56 m/s	1.56 m/s	1.56 m/s	1.56 m/s
Acceleration		1.48 m/s <sup>2</sup>	1.48 m/s <sup>2</sup>	1.48 m/s <sup>2</sup>	1.48 m/s <sup>2</sup>	1.48 m/s <sup>2</sup>
<b>X AXIS</b>						
Travel length (TL)			2000 mm		2000 mm	3100 mm
Maximum speed	50% duty cycle		1.50 m/s		1.50 m/s	1.50 m/s
Acceleration			1.76 m/s <sup>2</sup>		1.76 m/s <sup>2</sup>	1.76 m/s <sup>2</sup>
Travel	0.5 / 1.0 m 1.5 / 2.0 m		0.94 / 1.31 s 1.64 / 1.97 s		0.94 / 1.31 s 1.64 / 1.97 s	0.94 / 1.31 s 1.64 / 1.97 s
<b>Z AXIS</b>						
Travel length (TL)				1500 mm	1500 mm	1500 mm
Maximum speed	50% duty cycle			0.57 m/s	0.57 m/s	0.57 m/s
Acceleration				1.90 m/s <sup>2</sup>	1.90 m/s <sup>2</sup>	1.90 m/s <sup>2</sup>
Travel	0.5 / 1.0 / 1.5 m			1.22 / 2.09 / 2.97 s	1.22 / 2.09 / 2.97 s	1.22 / 2.09 / 2.97 s



Rail track

Gantry

Cantilever

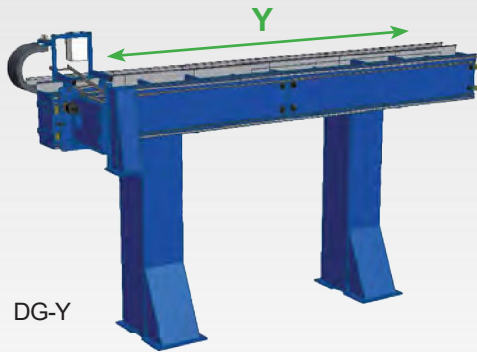

DG-Y

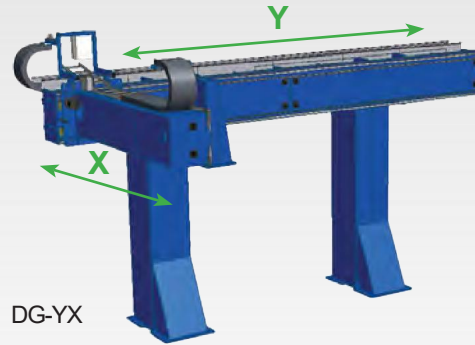

DG-YX

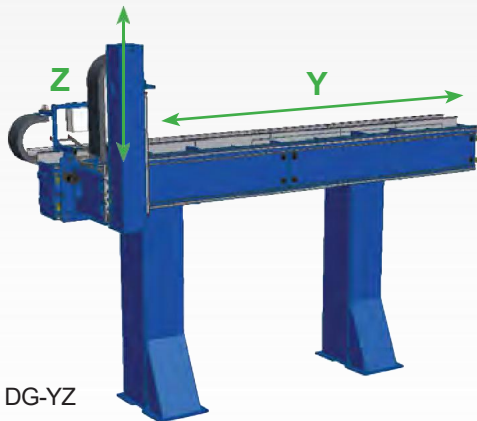

DG-YZ

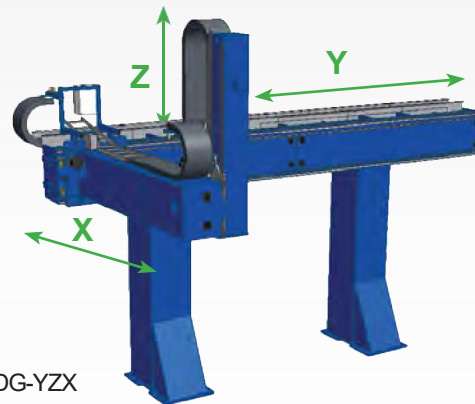

DG-YZX



---

# 04

# Control SYSTEM

---

01: RC BOX

02: PLC BOX

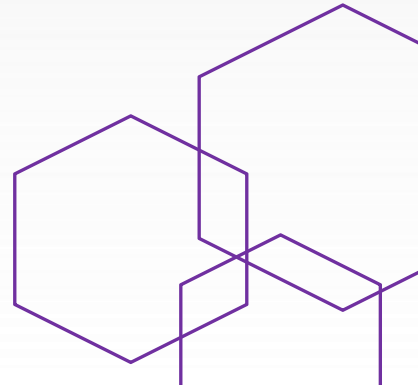



# External axes and DR10

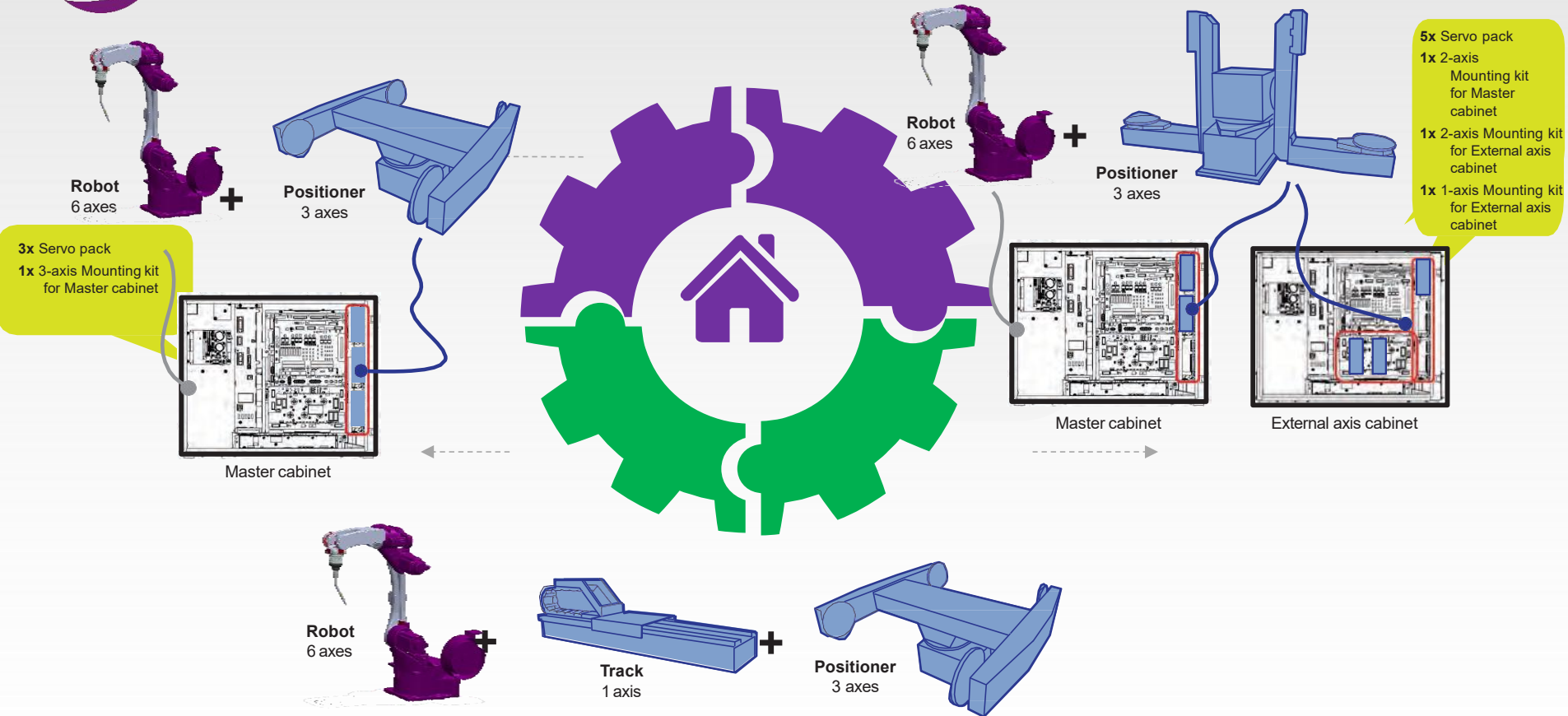



# External axes and DR10

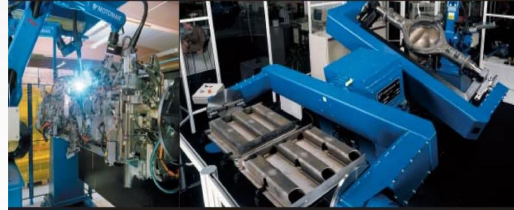



**DESAN**

